

# 28 Gb/s duobinary signal transmission over 40 km based on 10 GHz DML and PIN for 100 Gb/s PON

Zhengkuan Li, Lilin Yi,\* Xiaodong Wang, and Weisheng Hu

State Key Lab of Advanced Optical Communication Systems and Networks, Shanghai Jiao Tong University,  
Department of Electronic Engineering, Shanghai 200240, China

\*lilinyi@sjtu.edu.cn

**Abstract:** In this paper, we demonstrate the direct modulation and direct detection of 28-Gb/s duobinary signal for the future downstream capacity upgrade in next generation passive optical network (PON). Commercial 10-GHz directly modulated laser (DML) and PIN with a combined modulation bandwidth of  $\sim 7$  GHz are used as transmitter and receiver respectively. In order to mitigate the chromatic dispersion induced signal distortion, an optical delay interferometer (DI) is employed to narrow down the signal spectrum, thereby realizing 40-km single mode fiber (SMF) transmission in C-band. Besides, the chirp-induced spectral broadening of the directly modulated signal enables a higher launch power than external modulation schemes, which increases the loss budget of the system. As a result, 31-dB loss budget is achieved, supporting 64 users with 40-km reach. Also, as the transceivers in both optical line terminal (OLT) and optical network unit (ONU) are commercial 10-GHz devices, the proposed scheme is compatible with 40-Gb/s time and wavelength division multiplexing passive optical network (TWDM-PON) systems, providing a cost-efficient alternative for the development of 100G PON.

©2015 Optical Society of America

**OCIS codes:** (060.2330) Fiber optics communications; (060.2360) Fiber optics links and subsystems.

---

## References and links

1. Y. Luo, X. Zhou, F. Effenberger, X. Yan, G. Peng, Y. Qian, and Y. Ma, "Time- and wavelength-division multiplexed passive optical network (TWDM-PON) for next-generation PON Stage 2 (NG-PON2)," *J. Lightwave Technol.* **31**(4), 587–593 (2013).
2. L. Yi, Z. Li, M. Bi, W. Wei, and W. Hu, "Symmetric 40-Gb/s TWDM-PON with 39-dB power budget," *IEEE Photonics Technol. Lett.* **25**(7), 644–647 (2013).
3. S. Bindhaiq, A. S. M. Supa'at, N. Zulkifli, A. B. Mohammad, R. Q. Shaddad, M. A. Elmagzoub, and A. Faisal, "Recent development on time and wavelength-division multiplexed passive optical network (TWDM-PON) for next-generation passive optical network stage 2 (NG-PON2)," *J. Opt. Switch. Network* **15**, 53–66 (2015).
4. H. Zhang, S. Fu, J. Man, W. Chen, X. Song, and L. Zeng, "30-km Downstream Transmission Using  $4 \times 25$  Gb/s 4-PAM modulation with commercial 10Gbps TOSA and ROSA for 100Gb/s-PON," in *Proc. OFC 2014*, paper M21.3.
5. Y. Luo, B. Lin, H. Yang, J. Li, Y. He, Z. Chen, and Z. Li, "Symmetric 100-Gb/s TWDM-PON with DSB OFDM modulation," in *Proc. OFC 2014*, paper W2A.61.
6. Y. Kim, J. Lee, Y. Kim, and J. Jeong, "Evaluation of transmission performance in cost-effective optical duobinary transmission utilizing modulator's bandwidth or low-pass filter implemented by a single capacitor," *Opt. Fiber Technol.* **10**(4), 312–324 (2004).
7. D. van Veen, V. E. Houtsma, P. Winzer, and P. Vetter, "26-Gbps PON Transmission over 40-km using duobinary detection with a low cost 7-GHz APD-based receiver," in *Proc. ECOC 2012*, paper Tu.3.B.1.
8. L. Śliwczynski and P. Krehlik, "Increasing dispersion tolerance of 10Gbit/s directly modulated lasers using optical filtering," *Int. J. Electron. Commun.* **64**(5), 484–488 (2010).
9. J. D. Downie and R. S. Vodhanel, "Reach enhancement of a 10Gbps directly modulated laser with demultiplexer filtering," in *Proc. LEOS 2004*, paper ThE4.
10. T. Ono, Y. Yano, and K. Fukuchi, "Demonstration of high-dispersion tolerance of 20-Gbit/s optical duobinary signal generated by a low-pass filtering method," in *Proc. OFC 1997*, paper ThH1.

11. K. Yonenaga, S. Kuwano, S. Norimatsu, and N. Shibata, "Optical duobinary transmission system with no receiver sensitivity degradation," *Electron. Lett.* **31**(4), 302–304 (1995).
12. Y. Guo, S. Zhu, G. Kuang, Y. Yin, D. Zhang, and X. Liu, "Demonstration of a Symmetric 40 Gbit/s TWDM-PON over 40 km passive reach using 10 G burst-mode DML and EDC for upstream transmission [Invited]," *J. Opt. Commun. Netw.* **7**(3), A363–A371 (2015).
13. Z. Li, L. Yi, W. Wei, M. Bi, H. He, S. Xiao, and W. Hu, "Symmetric 40-Gb/s, 100-km passive reach TWDM-PON with 53-dB loss budget," *J. Lightwave Technol.* **32**(21), 3389–3396 (2014).
14. Q. Guo and A. V. Tran, "Demonstration of a 40 Gb/s wavelength-reused WDM-PON using coding and equalization [Invited]," *J. Opt. Commun. Netw.* **5**(10), A119–A126 (2013).
15. L. Yi, X. Wang, Z. Li, J. Huang, J. Han, and W. Hu, "Upstream dispersion management supporting 100 km differential reach in TWDM-PON," *Opt. Express* **23**(6), 7971–7977 (2015).
16. J. H. Sinsky, A. Konczykowska, A. L. Adamecki, F. Jorge, and M. Duelk, "39.4-Gb/s duobinary transmission over 24.4 m of coaxial cable using a custom indium phosphide duobinary-to-binary converter integrated circuit," *IEEE Trans. Microw. Theory Tech.* **56**(12), 3162–3169 (2008).
17. A. Adamecki, M. Duelk, J. Sinsky, and M. Mandich, "Scalability of duobinary signaling to 25 Gb/s for 100 GbE applications." IEEE 802.3ap working group presentation, November (2004).
18. L. F. Suhr, J. J. Vegas Olmos, B. Mao, X. Xu, G. N. Liu, and I. T. Monroy, "112-Gbit/s×4-lane duobinary-4-PAM for 400GBase," in *Proc. ECOC 2014*, paper Tu.4.3.2.
19. D. T. van Veen, V. E. Houtsma, A. H. Gnauck, and P. Iannone, "Demonstration of 40-Gb/s TDM-PON over 42-km with 31 dB optical power budget using an APD-based receiver," *J. Lightwave Technol.* **33**(8), 1675–1680 (2015).
20. J. Zhou, C. Yu, and H. Kim, "1.5- $\mu$ m, 10-Gbps 4-PAM VCSEL transmission for optical access networks," in *Proc. of International Conference on Optical Internet 2014*, paper FA2–3.
21. Y. Matsui, D. Mahgerefteh, X. Zheng, C. Liao, Z. F. Fan, K. McCallion, and P. Tayebati, "Chirp-managed directly modulated laser (CML)," *IEEE Photonics Technol. Lett.* **18**(2), 385–387 (2006).
22. H. Kim, "Transmission of 10-Gb/s directly modulated RSOA signals in single-fiber loopback WDM PONs," *IEEE Photonics Technol. Lett.* **23**(14), 965–967 (2011).
23. M. Bi, S. Xiao, L. Yi, H. He, J. Li, X. Yang, and W. Hu, "Power budget improvement of symmetric 40-Gb/s DML-based TWDM-PON system," *Opt. Express* **22**(6), 6925–6933 (2014).
24. Z. Li, L. Yi, and W. Hu, "Comparison of downstream transmitters for high loss budget of long-reach 10G-PON," in *Proc. OFC 2014*, paper Tu2C. 4.
25. C. Caillaud, P. Chanclou, F. Blache, P. Angelini, B. Duval, P. Charbonnier, D. Lanteri, and M. Achouche, "High sensitivity 40 Gbit/s preamplified SOA-PIN/TIA receiver module for high speed PON," in *European Conference on Optical Communication (ECOC, 2014)*, paper Tu 3.2.3.
26. D. Zhang, D. Sun, Y. Dong, L. Yi, H. He, Y. Mou and W. Hu, "Amplifierless 40-km SMF transmission for 100GE based on 4× 25-Gbps optical duo-binary at 1550 nm," in *International Conference on Optical Communications and Networks (ICOCN, 2011)*, pp. 1–2.

## 1. Introduction

Time and wavelength division multiplexing passive optical networks (TWDM-PON) has been admitted by both researchers and industries as the most promising solution for the construction of next generation PON stage 2 (NG-PON2). Based on the wavelength stacking technique, TWDM-PON can reuse the optical distribution network (ODN) and some of the already mature techniques in the current 10-Gb/s PON systems, thereby enabling a smooth and efficient upgrade. During the past few years, a lot of proposals on 40-Gb/s TWDM-PON have been presented for discussion [1–3], which promoted the standardization and commercialization process of NG-PON2. However, the 40-Gb/s capacity would not provide a long-term satisfaction for the desire of users, so researches for 100G-EPON come out right on the heels of NG-PON2. In order to relax the bandwidth requirement on devices, advanced modulation formats with higher spectral efficiency are required to realize high data rate modulation and detection on bandwidth-limited transceivers. Hongguang Zhang et al. have demonstrated 30-km transmission of 25-Gb/s four-level pulse amplitude (4-PAM) signal based on 10-Gbps transmitter optical subassembly (TOSA) and receiver optical subassembly (ROSA) [4], where electrical equalizer is required in the receiving side to equalize the frequency response and compensate the chromatic dispersion during fiber transmission. Yuanbao Luo et al. presented a double sideband (DSB) orthogonal frequency division multiplexing (OFDM) based symmetric 100-Gb/s TWDM-PON, where 26.7-km fiber transmission is realized by using Mach-Zehnder modulator (MZM) and digital signal processing (DSP) in both optical line terminal (OLT) and optical network unit (ONU) sides [5]. Duobinary format has also been proposed by using a bandwidth-limited device either at the transmitter [6] or receiver side [7], where the high data rate signals are required to be

externally modulated or transmitted in O-band to avoid the chromatic dispersion induced signal distortion.

In this paper, we demonstrate 40-km downstream transmission of 28-Gb/s duobinary signal in C-band using transmitter and receiver both operating at 10-GHz bandwidth. Instead of external modulation, the signal is directly modulated on a distributed feedback (DFB) laser. Taking advantage of the low pass filtering characteristic of the directly modulated laser (DML) and the PIN detector, the 28-Gb/s on-off-keying (OOK) signal is converted into duobinary format at the receiving side. And in order to mitigate the signal distortion induced by the interaction between frequency chirp of the DML and the chromatic dispersion in fiber, an optical delay interferometer (DI) is employed to reshape the signal spectrum [8, 9], thereby realizing 40-km single mode fiber (SMF) transmission in C-band with only 1.2-dB penalty compared to back-to-back (BtB) case. Moreover, due to the chirp-induced spectral broadening, the directly modulated signal shows a high tolerance to fiber nonlinearity, and no distortion is observed until the launch power exceeds 16 dBm. Finally, 31-dB loss budget is achieved, which could support 64 users within 40-km reach.

## 2. 10-GHz devices based OOK-Duobinary format conversion

Duobinary format has been discussed a lot during the construction of 100G Ethernet networks. As a partial-response signal, duobinary format has a narrower bandwidth compared to binary format, making it more suitable for high speed modulation and transmission. Generally, the duobinary signal is generated by low-pass filtering or delay-and-add filtering of a pre-encoded data sequence to obtain three-level pulses [10, 11]. The 3-dB bandwidth of the low-pass filter should be 0.25 times of the signal bit rate to realize an effective format conversion. The green curve in Fig. 1 depicts the frequency response of the 5th order Bessel low-pass filter required for generating 28-Gb/s duobinary signal, which has a 3-dB bandwidth of  $\sim 7$  GHz. Inset (i) is the corresponding eye diagram of the filtered signal. On the other hand, using bandwidth-limited devices for data modulation or detection can also convert the binary signal to three levels [6, 7]. Fig. 1 shows the frequency responses of a 10-GHz directly modulated DFB laser (XGT-9005A-P08-C1) with a 30-GHz PIN and a 10-GHz PIN (Conquer-KG-PR-10G) with a 20-GHz MZM measured by a vector network analyzer. The combined frequency response of the 10-GHz DFB and 10-GHz PIN is also depicted, which well matches with the response of the ideal Bessel low-pass filter within the 0-10 GHz frequency region. Therefore, when we modulate 28-Gb/s OOK signal with the 10-GHz DML and then detect it with the 10-GHz PIN, the received signal can be successfully converted into duobinary format, as inset (ii) shows. After detection, the received duobinary signal can be decoded back to binary sequence by a real-time decision circuit [12] or by analog to digital converter (ADC) with DSP. In this way, 28-Gb/s direct modulation and direct detection can be realized using the same transmitters and receivers as in the  $4 \times 10$ -Gb/s systems [13] and no high-frequency components are required, providing a cost-effective solution for the further capacity upgrade of next generation PON systems. In the following section, we will further investigate the fiber transmission and bit error ratio (BER) performance of the proposed scheme by experiment.

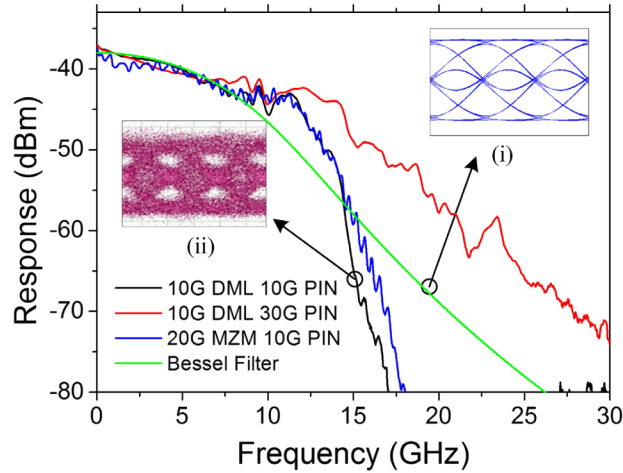

Fig. 1. Frequency response and the corresponding eye diagram of the 10-GHz DML combined with the 10-GHz PIN

### 3. Proposed 100-Gb/s TWDM-PON scheme

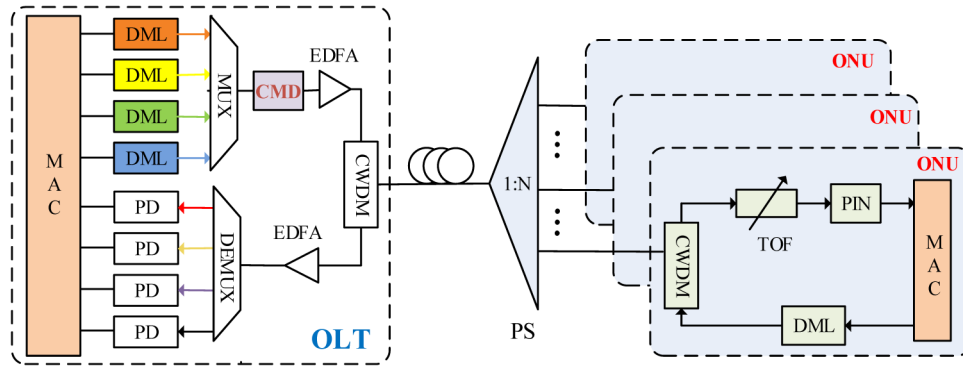

Fig. 2. Proposed 100-Gb/s TWDM-PON system. CMD: chirp management device. PS: power splitter; TOF: tunable optical filter.

Figure 2 depicts the network architecture of the proposed 100-Gb/s TWDM-PON system. In the OLT side, 4 DMLs operating at different wavelengths are used as transmitters. Note that the data rate on each channel is 28 Gb/s instead of 25 Gb/s because some overheads should be reserved for signal processing such as forward error correction (FEC) etc. The outputs of DMLs are combined by an optical multiplexer (MUX). Then an erbium doped fiber amplifier (EDFA) boosts the signal power before being launched into the fiber for loss budget improvement. After fiber transmission, the signal is distributed to all ONUs by a power splitter. The tunable optical filter (TOF) in each ONU selects the specified wavelength and then launches the signal into the PIN for detection. Finally, the received electrical signal in duobinary format is demodulated back to binary signal by DSP. The coarse wavelength division multiplexers (CWDm) in the network are used for separating upstream and downstream wavelengths. In this scheme, as DML is used for transmitting 28-Gb/s signal, a chirp management device (CMD) is required to eliminate the chromatic dispersion induced signal distortion during fiber transmission.

As for the upstream link, due to the traffic asymmetry, the data rate requirement is expected to be lower than the downstream link. Therefore we suppose the 10-Gbps techniques

are sufficient [14, 15]. Therefore, we just focus on the downstream link in the following experimental demonstrations and performance investigations.

#### 4. Experimental setup and results

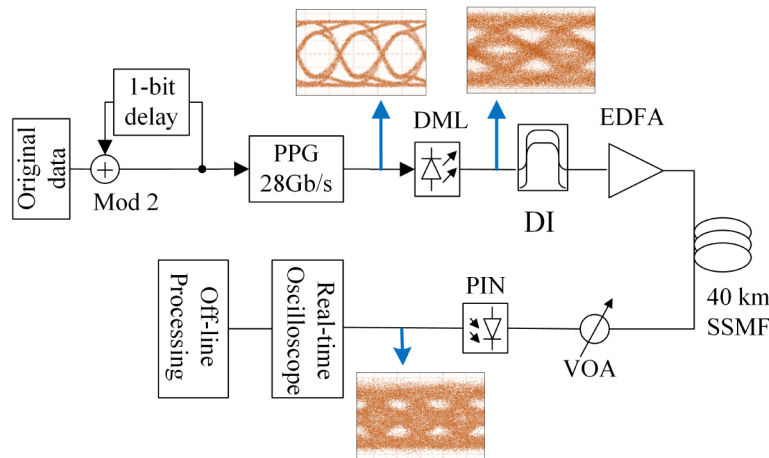

Fig. 3. Experimental setup

The experimental setup is shown in Fig. 3. Only a single channel is demonstrated for the proof of concept. In order to avoid error propagation, the original binary data are pre-encoded to remove the correlations between the received bits. The encoded data is imported into a pulse pattern generator (PPG) operating at 28 Gb/s to get the OOK signal output. Then the signal is modulated onto the commercially available DML operating at 10 GHz. The output wavelength of the DML is  $\sim 1543$  nm under room temperature, and it can be thermally tuned within  $\sim 3$  nm range. Before being launched into the fiber, the signal passes through a DI based chirp management device for chirp elimination, and an EDFA follows behind to boost the launch power. After 40-km SMF transmission, the signal is attenuated by a variable optical attenuator (VOA), which emulates the function of power splitter in the ODN and varies the optical power for bit-rate error (BER) testing. Then the signal is launched into the receiver for detection. As previously illustrated in section 2, the receiver in the ONU is a 10-GHz PIN. And the combination of the transmitter and receiver gives a 3-dB frequency response bandwidth of  $\sim 7$  GHz, as depicted in Fig. 1. We can see from the eye diagrams in Fig. 3 that the original OOK signal is converted into duobinary format by the bandwidth-limited modulation at the transmission side, while the low-pass filtering property of the PIN at the receiving side further closes the middle eye. The received duobinary signal is sampled by digital storage oscilloscope (DSO) with 80-GS/s real-time sample rate. The 3-level to 2-level signal demodulation and BER calculation are realized by off-line DSP in Matlab. Note that the off-line DSP is required just for level determining and BER calculating, and no signal recovery module such as equalization, dispersion compensation is applied. Therefore the function of ADC together with the off-line DSP equals to a real-time duobinary signal detection circuit [16], which is not available in our lab at present. As duobinary format has been discussed a lot during the development of 100G Ethernet, the related techniques are already quite mature [17, 18]. Note that due to the high data rate of the signal, the detection circuit requires fast electronics, and the same problem exists for PAM-4 format, too. The decision for OOK format is simpler but the bandwidth requirement on devices is higher, which also increases the cost. Therefore, a comprehensive comparison between these formats should be made for an optimal choice.

In the proposed scheme, the chirp management device is a key component to enable the distortion-free transmission of directly modulated signal. Generally, direct modulation results in strong frequency chirp, which interacts with the chromatic dispersion of the fiber to change

the pulse shape of the signal during transmission. As a result, the signal is severely distorted after long distance fiber transmission. To alleviate the influence, dispersion compensating techniques should be used, such as dispersion pre-compensation [19], electronic equalization [20], etc. Considering the electronic bottleneck, optical processing is preferred for high data rate signal processing. In our scheme, a DI is employed as the optical chirp management device. Figure 4 depicts the transmission property of the DI, which performs as a notch filter for signal spectral reshaping. When we position the central frequency of the DML on the falling edge of the filter, the signal spectrum will be narrowed and the long-wavelength spectral components will be reduced. It has been verified that after spectral reshaping, the frequency profile of the bit sequences will become flat-topped, thereby creating nearly chirp-free pulses [21]. In this case, the signal will have a higher tolerance to chromatic dispersion. Experimental results show that after 20-km and 40-km transmission, almost no signal distortion is observed as Figs. 5(d) and 5(f) show, proving the feasibility of the spectral reshaping based chirp management solution for high bit rate directly-modulated duobinary signals. We also investigate the requirement on the transmission property of the DI. It turns out that only when the central frequency of the signal spectrum is aligned with the falling edge of the filter, the dispersion induced signal distortion is eliminated, meaning that the chirp management performance is quite sensitive to wavelength drifts just like in 10-Gb/s situations [22, 23]. Experimental results show that the sensitivity penalty is lower than 1-dB when the frequency offset drifts within  $\pm 1.5$  GHz. But  $\sim 3$ -dB penalty is observed when the frequency deviation is  $\pm 3$  GHz. Therefore, the central frequency of the DML and DI should be precisely controlled, or a feedback circuit is required to keep the wavelength offset stable as in the commercial chirp-managed laser (CML) design. In spite of this, the requirement on the free-spectral range (FSR) of the DI is proved to be quite loose, because similar performances are obtained when we vary the FSR from 0.4 nm to 2 nm. In this way, as long as the FSR of the DI is set as an integral multiple of the channel space, multi-channel chirp management can be realized by a single device.

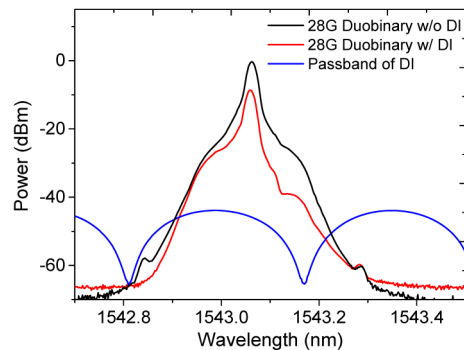

Fig. 4. Optical spectrum of the duobinary signal before and after chirp management

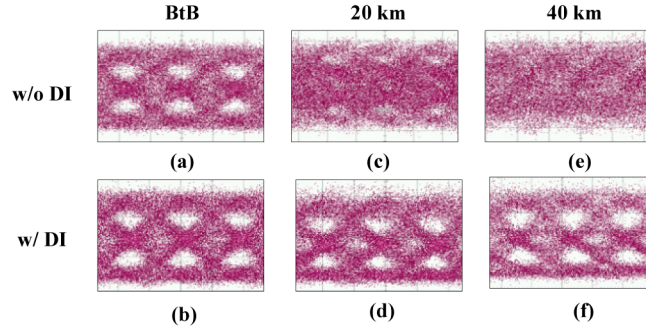

Fig. 5. Eye diagrams measurement

We have demonstrated in our previous work that due to the chirp induced spectral broadening, the directly modulated binary signal has a high tolerance to fiber nonlinearity, thereby enabling a high launch power [24]. Similarly, for the three-level duobinary signal, no distortion is observed until the launch power exceeds 16 dBm. Then we evaluate the BER performance of the received duobinary signal. After the decision and decoding processes, the signal is converted from duobinary into binary format. And by comparing with the original sequence, the BER of the received signal is obtained. We vary the attenuation values of the VOA and measure the BER in each case respectively. The calculated BER curves are shown in Fig. 6. The sensitivity in BtB case is about  $-16.3$  dBm when we take the FEC threshold of  $3.8 \times 10^{-3}$  for evaluation. 20-km fiber transmission introduces  $\sim 1$ -dB penalty, resulting in a sensitivity of  $\sim -15$  dBm. And the signal experiences an extra 0.2-dB penalty when the transmission distance is increased to 40 km. Taking the 16-dBm launch power into consideration, the proposed scheme has 31-dB loss budget, which could support 1:64 splitting ratio with 40-km fiber reach. Note that the receiving power refers to the power launched into the PIN. For multi-channel applications, a TOF with  $\sim 3$ -dB insertion loss is required to be considered, thereby reducing the loss budget by  $\sim 3$  dB. Besides, the launch power is generally limited because of the relevant eye-safety regulations, which also restricted the loss budget of the system. To solve this problem, we can replace the PIN with an APD for sensitivity improvement. Otherwise, using a semiconductor optical amplifier (SOA) for pre-amplification has also been proposed as a potential solution for increasing receiving sensitivity [25]. But for some special scenarios that require a higher loss budget, the high nonlinear tolerance property of directly modulated signal will be a significant advantage providing that some protection techniques are introduced.

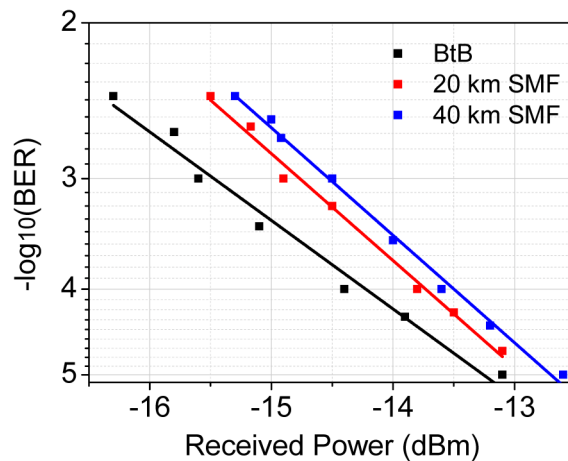

Fig. 6. Measured BER curve

By the experimental demonstration, we have verified the feasibility of using DML as transmitter for 28-Gb/s data modulation. Experimental results demonstrate that thanks to the spectral reshaping function of the DI, the directly modulated signal shows a chromatic dispersion tolerance even better than the external modulated optical duobinary signal. Only 1.2-dB sensitivity penalty is observed for 40-km fiber transmission in our experiment while the penalty for external modulated optical duobinary signal is 5 dB [26]. Thus, the combination of DML and spectral reshaping filter provides a potential solution for the capacity upgrade in future PON systems.

## 5. Conclusions

In this paper, we demonstrate the direct modulation and direct detection with 40-km fiber transmission of 28-Gb/s signal. Taking advantage of the bandwidth-limited characteristic of the devices, the 28-Gb/s OOK signal is converted into duobinary format when a commercial 10-GHz transmitter and 10-GHz receiver are used for modulation and detection. To eliminate the strong frequency chirp originated from direct modulation, we use a DI to reshape the spectrum of the signal. As a result, almost chirp-free signal is obtained with only 1.2-dB penalty after 40-km fiber transmission. Also, due to the chirp-induced broad spectrum characteristic of directly modulated signal, the launch power can be as high as 16 dBm. The loss budget of the system is evaluated to be 31 dB, which could support 64 users within 40-km reach. The proposed scheme provides a low-cost solution for a smooth capacity upgrade of next generation PON systems.

## Acknowledgments

This work was supported by National Basic Research Program of China (2012CB315602), National Natural Science Foundation of China (61322507 and 61132004) and Program of Excellent PhD in China (201155)